

GENERAL SPECIFICATION OF D940TW ULTRA SPEED DIGITAL SERVO

1. TECHNICAL VALUE

CONTROL SYSTEM	:+PULSE WIDTH CONTROL 1500usec NEUTRAL		
OPERATING VOLTAGE RANGE	:6.0V TO 7.4V		
OPERATING TEMPERATURE RANGE	:-20°C TO +60°C(-4°F TO +140°F)		
TEST VOLTAGE	:4.8V	AT 6.0V	AT 7.4V
OPERATING SPEED	:0.11sec/60°	0.08sec/60°	0.07sec/60°
STALL TORQUE	:10.0kg.cm(138.87oz.in)	13.5kg.cm(187.48oz.in)	16.5kg.cm(229.14oz.in)
STANDING TORQUE	:-		
IDLE CURRENT	:30mA AT STOPPED	30mA AT STOPPED	30mA AT STOPPED
RUNNING CURRENT	:390mA	390mA	500mA
STALL CURRENT	:3,700mA	4,800mA	6,200mA
DEAD BAND WIDTH	:1usec	1usec	1usec
OPERATING TRAVEL	:ONE SIDE PULSE TRAVELING 400usec		
DIRECTION	:CLOCK WISE/PULSE TRAVELING 1500 TO 1900usec		
MOTOR TYPE	:CORELESS METAL BRUSH		
POTENTIOMETER TYPE	:4 SLIDER/1M CYCLE LONG LIFE/INDIRECT DRIVE		
AMPLIFIER TYPE	:ATMEGA48 MCU DIGITAL AMPLIFIER WITH MOSFET DRIVE		
DIMENSIONS	:40x20x38mm(1.57x0.79x1.50in)		
WEIGHT	:68g(2.40oz)		
BALL BEARING	:DUAL/MR106		
GEAR MATERIAL	:1 METAL-PLASTIC & 3 TITANIUM ALLOY		
HORN GEAR SPLINE	:25 SEGMENTS/ø6.0		
SPLINED HORNS	:HEAVY DUTY/HD-IS25, HD-OS25, HD-LS25, HD-IL25, HD-LL25		
CONNECTOR WIRE LENGTH	:300mm(11.81in)		
CONNECTOR WIRE STRAND COUNTER	:80EA		
CONNECTOR WIRE GAUGE	:20AWG		

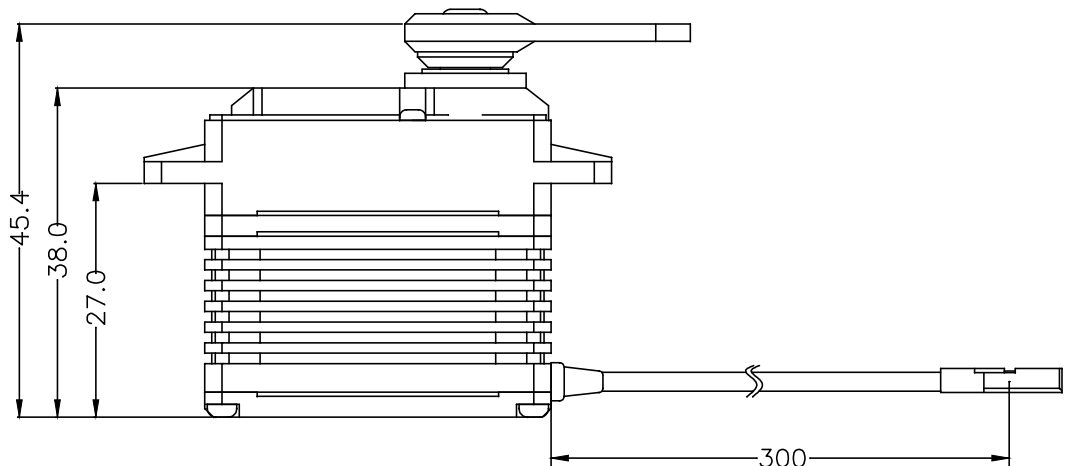
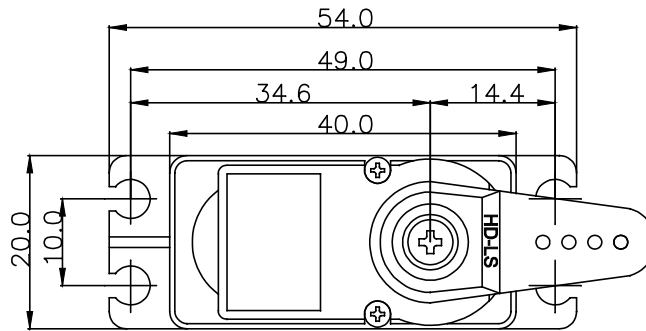

2. FEATURES

- PROGRAMMABLE DIGITAL AMPLIFIER WITH MOSFET DRIVE
- DURABLE TITANIUM ALLOY METAL GEARS WITH DUAL BALL BEARING
- ULTRA HARDNESS GEAR SHAFT WITH 3 AXIAL METAL BUSHING
- WATER & DUST RESISTANCE
- HEAT SINK FOR MOTOR

3. APPLICATIONS

- LARGE AIR PLANE MODELS