

GENERAL SPECIFICATION OF D980TW MONSTER TORQUE DIGITAL SERVO

1. TECHNICAL VALUE

CONTROL SYSTEM	:+PULSE WIDTH CONTROL 1500usec NEUTRAL		
OPERATING VOLTAGE RANGE	:6.0V TO 7.4V		
OPERATING TEMPERATURE RANGE	:-20°C TO +60°C(-4°F TO +140°F)		
TEST VOLTAGE	:AT 4.8V	AT 6.0V	AT 7.4V
OPERATING SPEED	:0.28sec/60°	0.21	0.17sec
STALL TORQUE	:26.0kg.cm(500oz.in)	36.0kg.cm(500oz.in)	44.0kg.cm(611oz.in)
STANDING TORQUE	:-		
IDLE CURRENT	:30mA	30mA	30mA
RUNNING CURRENT	:300mA	390mA	500mA
STALL CURRENT	:4,800mA	4,800mA	6,200mA
DEAD BAND WIDTH	:1usec	1usec	1usec
OPERATING TRAVEL	:40±5°/ONE SIDE PULSE TRAVELING 400usec		
DIRECTION	:CLOCK WISE/PULSE TRAVELING 1500 TO 1900usec		
MOTOR TYPE	:CORELESS METAL BRUSH		
POTENTIOMETER TYPE	:4 SLIDER/1M CYCLE LONG LIFE/INDIRECT DRIVE		
AMPLIFIER TYPE	:ATMEGA48 MCU DIGITAL AMPLIFIER WITH MOSFET DRIVE		
DIMENSIONS	:43.8x22.4x40.0mm(1.72x0.88x1.57in)		
WEIGHT	:78.2g(2.76oz)		
BALL BEARING	:DUAL/MR106		
GEAR MATERIAL	:1 METAL-PLASTIC & 3 TITANIUM ALLOY		
HORN GEAR SPLINE	:25 SEGMENTS/ø6.0		
SPLINED HORNS	:HEAVY DUTY/HD-OS25, HD-LS25, HD-IL25, HD-LL25, HD-LG25, HD-IG25		
CONNECTOR WIRE LENGTH	:300mm(11.81in)		
CONNECTOR WIRE STRAND COUNTER	:80EA		
CONNECTOR WIRE GAUGE	:20AWG		

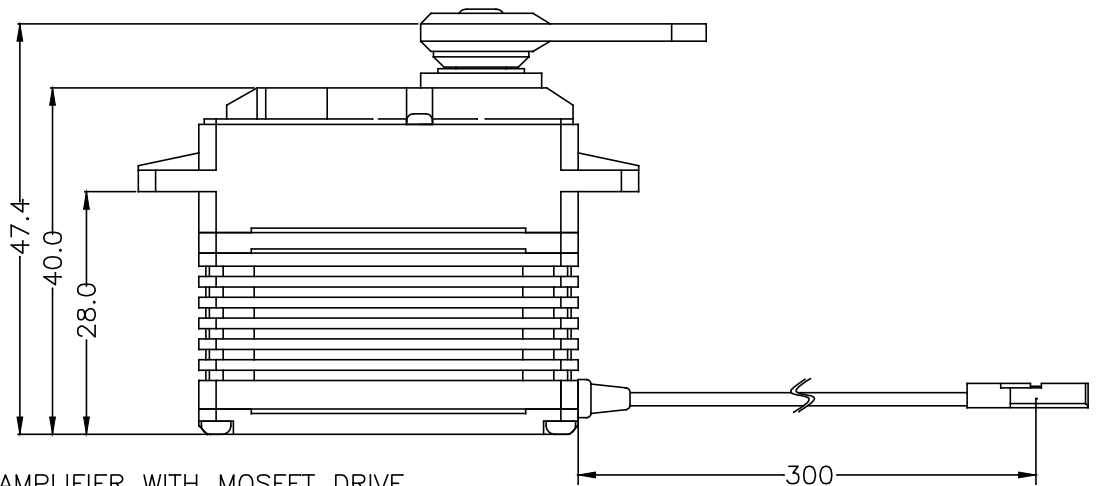
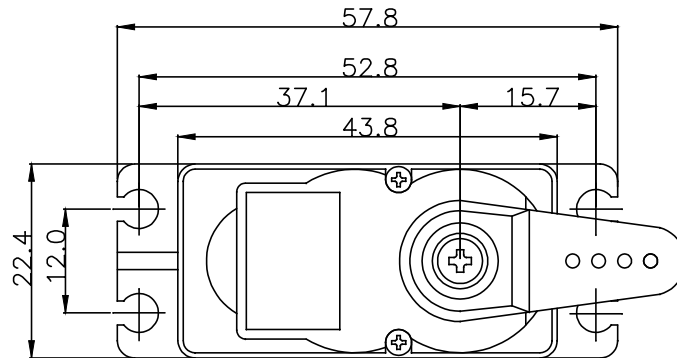

2. FEATURES

- PROGRAMMABLE DIGITAL AMPLIFIER WITH MOSFET DRIVE
- DURABLE TITANIUM ALLOY METAL GEARS WITH DUAL BALL BEARING
- SEMPERMANENT MAGNETIC ROTARY ENCODER
- ULTRA HARDNESS GEAR SHAFT WITH 4 AXIAL METAL BUSHING
- WATER & DUST RESISTANCE
- HEAT SINK FOR MOTOR & MOSFET

3. APPLICATIONS

- LARGE AIR PLANE MODELS