

GENERAL SPECIFICATION OF HSB-9465SH HIGH VOLTAGE BLDC SERVO

1. TECHNICAL VALUE

CONTROL SYSTEM	: +PULSE WIDTH CONTROL 1500usec NEUTRAL	
OPERATING VOLTAGE RANGE	: 6.0V TO 7.4V	
OPERATING TEMPERATURE RANGE	: -20°C TO +60°C (-68°F TO +140°F)	
TEST VOLTAGE	: AT 6.0V	AT 7.4V
OPERATING SPEED	: 0.09sec/60° AT NO LOAD	0.07sec/60° AT NO LOAD
STALL TORQUE	: 13.5kg.cm(187.48oz.in)	13.5kg.cm(187.48oz.in)
STANDING TORQUE	: -	-
IDLE CURRENT	: 30mA AT STOPPED	30mA AT STOPPED
RUNNING CURRENT	: 250mA/60° AT NO LOAD RUNNING	200mA/60° AT NO LOAD RUNNING
STALL CURRENT	: 1100mA	900mA
DEAD BAND WIDTH	: 1usec	1usec
OPERATING TRAVEL	: ONE SIDE PULSE TRAVELING 400usec	
DIRECTION	: CLOCK WISE/PULSE TRAVELING 1500 TO 1900usec	
MOTOR TYPE	: BLDC	
POTENTIOMETER TYPE	: 4 SLIDER/1M CYCLE LONG LIFE/INDIRECT DRIVE	
AMPLIFIER TYPE	: DSPIC33 MCU DIGITAL AMPLIFIER WITH MOSFET DRIVE	
DIMENSIONS	: 40x20x37mm(1.57x0.78x1.45in)	
WEIGHT	: 65g(2.29oz)	
BALL BEARING	: DUAL/MR106	
GEAR MATERIAL	: 1 METAL-KARBONITE, 3 METAL GEARS	
HORN GEAR SPLINE	: 25 SEGMENTS /ø6.0	
SPLINED HORNS	: HEAVY DUTY/ LS25, IM25, X25, OS25, IL25, LL25	
CONNECTOR WIRE LENGTH	: 300mm(11.81in)	
CONNECTOR WIRE STRAND COUNTER	: 80EA	
CONNECTOR WIRE GAUGE	: 20AWG	

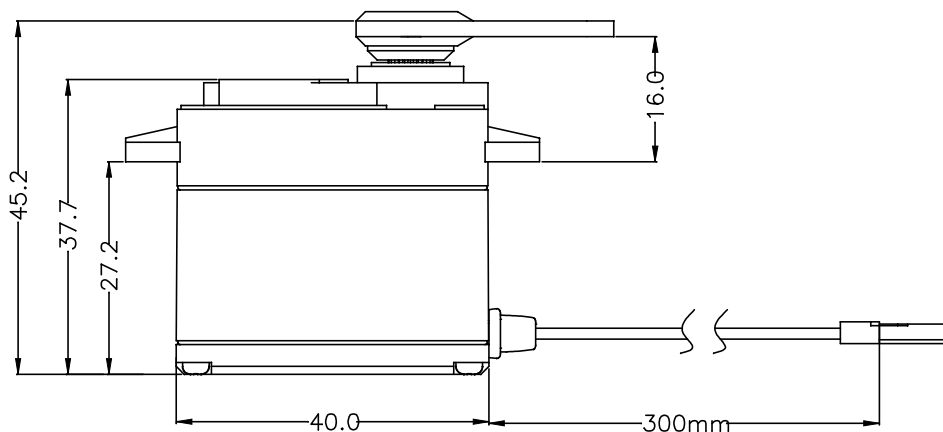
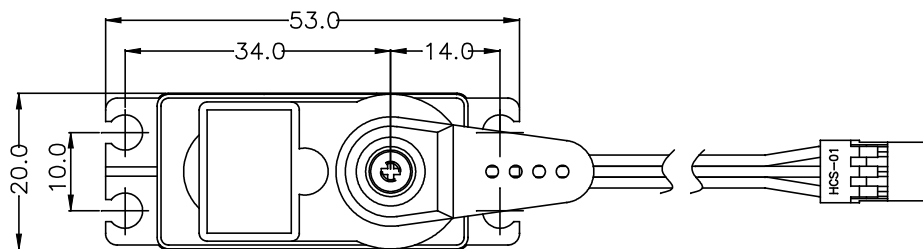

2. FEATURES

PROGRAMMABLE DIGITAL AMPLIFIER WITH BLDC MOTOR
DURABLE HEAVY DUTY METAL GEARS WITH BALL BEARING
WATER & DUST TIGHT

3. APPLICATIONS

AIRCRAFT 20-60 SIZE, 60 SIZE HELICOPTERS, STEERING AND THROTTLE SERVO, TRUCK AND BOATS